

Aug. 29, 1939.

F. H. KISLINGBURY

2,171,430

MUSICAL INSTRUMENT

Filed July 26, 1937

Fig. 1.

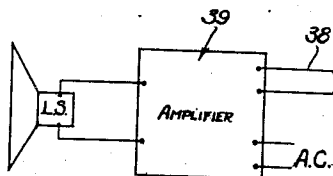
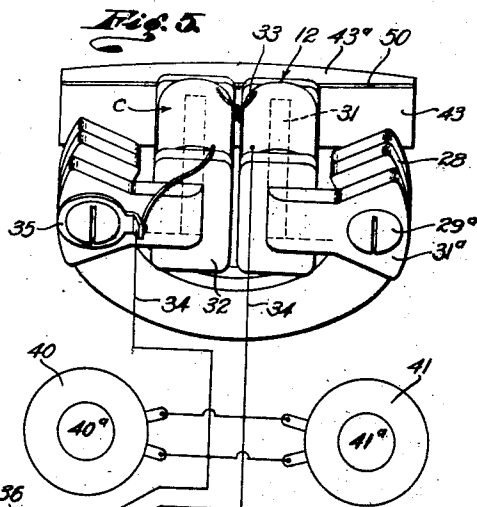
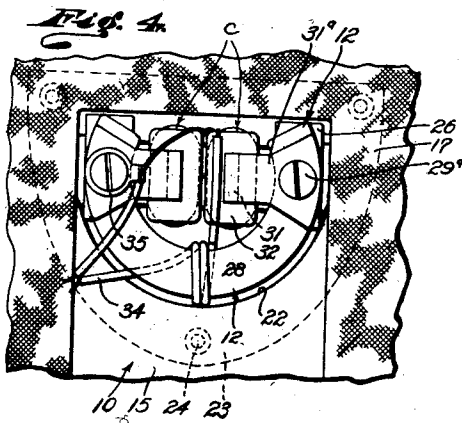
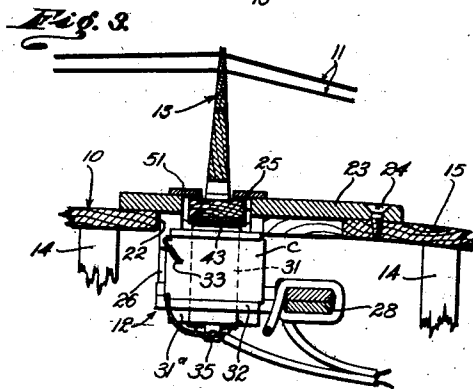
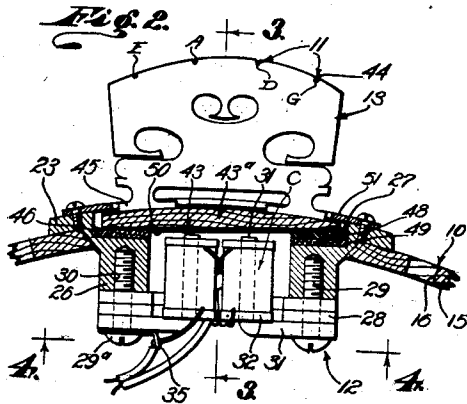
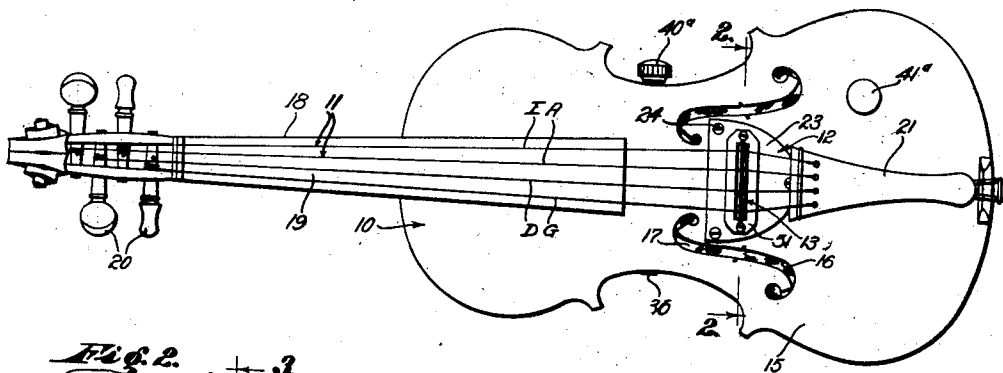

Inventor  
FREDRAY H. KISLINGBURY  
BY  
W. H. Hill  
His Attorney

# UNITED STATES PATENT OFFICE

2,171,430

## MUSICAL INSTRUMENT

Fredray H. Kislingbury, Los Angeles, Calif., assignor to Emil E. Dopyera, Los Angeles, Calif.

Application July 26, 1937, Serial No. 155,665

7 Claims. (Cl. 179—109)

This invention relates to musical instruments and relates more particularly to stringed musical instruments embodying electro-magnetic pick-up means. A general object of this invention is to

- 5 provide a practical, effective stringed musical instrument embodying a novel electrical pick-up operable to convert the vibrations of the strings into an electrical current having the characteristics of the vibrations of the strings.
- 10 Another object of this invention is to provide a stringed musical instrument of the violin class embodying an electro-magnetic pick-up unit that is operable to produce a varying or modulated electric current suitable for conversion into sound
- 15 by an amplifying and loud speaker unit that permits the employment of vibratory strings of any character whereby the musician may provide the instrument with gut strings, metal strings, gut strings wound with silk or wire, or any other
- 20 selected kinds of strings and may tension such strings as desired to obtain tones of the character, timbre and quality desired.

Where I herein employ the term "instrument of the violin class" I mean instruments such as

25 violins, cellos, violon-cellos, bass viols, guitars, ukeleles, etc.

- Another object of this invention is to provide an instrument of the character mentioned in which the electro-magnetic pick-up creates a modulated
- 30 electric current that may be converted into sound having the timbre, tonal qualities and other characteristics of the tones produced by the conventional instruments of the violin class. The instruments heretofore introduced having electrical
- 35 pick-up devices have not been capable of faithfully or accurately reproducing violin tones. The instrument of the present invention, on the other hand, is operable to produce tones that are true violin type instrument tones and that are without
- 40 the metallic sound and harshness found in the tones produced by most electrical musical instruments.

- Another object of this invention is to provide an instrument of the character mentioned in which
- 45 the vibrations of the bass strings, for example the D and G strings of a violin, are given dominance or brought out with greater distinctness than the higher strings or the E and A strings, whereby the desired cello tones may be produced by the musician with ease. In the typical violin and in the usual instrument of this class having an electrical
- 50 pick-up the E string being of small diameter and under relatively high tension, produces tones that dominate the tones of the heavier strings. In the instrument provided by the present invention this
- 55

inequality is overcome or lessened to the extent that tones of the heavier strings may be given dominance whereby the instrument is better balanced and easier to play.

Another object of this invention is to provide an instrument of the character mentioned that may be of the same size, shape and appearance as an ordinary violin or violin class instrument and has very little more weight than the average non-electrical instrument, to be handled and played in

10 the same manner as a typical violin type instrument.

Another object of this invention is to provide an instrument of the character mentioned in which the body or sound box of the instrument is substantially non-vibratile and incapable of producing vibrations that may affect the electrical pick-up means.

15

Another object of this invention is to provide an electrical stringed instrument of the character mentioned embodying a novel "floating" bridge carried by the diaphragm or armature of the pick-up unit.

20

A further object of this invention is to provide a particularly effective electro-magnetic pick-up unit that is light in weight, small and compact, and adapted to be embodied in a typical stringed instrument with but slight modification of the usual instrument construction.

25

The various objects and features of my invention will be fully understood from the following detailed description of a typical preferred form and application of the invention, throughout which description reference is made to the accompanying drawing, in which:

30

Fig. 1 is a top or plan view of an instrument of the present invention. Fig. 2 is an enlarged fragmentary vertical detailed sectional view taken as indicated by line 2—2 on Fig. 1, illustrating the principal parts of the pick-up. Fig. 3 is a fragmentary vertical detailed sectional view taken as indicated by line 3—3 on Fig. 2. Fig. 4 is a fragmentary bottom elevation of the pick-up being a view taken as indicated by line 4—4 on Fig. 2, and Fig. 5 is a perspective view of the under side

40

45 of the pick-up unit apart from the instrument body with a wiring diagram of the circuits embodied in the instrument.

The improved stringed instrument of the present invention includes, generally, a body 10, a plurality of tensioned vibratile strings 11 carried by the body 10, and an electrical magnetic pick-up 12 on the body 10 carrying a floating bridge 13 which engages the strings 11 between their ends.

50

The body 10 of the musical instrument may be

55

of the same size, shape and construction as the body of an ordinary instrument or typical stringed instrument. For example, where the invention is embodied in a violin as illustrated in the drawing the body 10 may be constructed of wood and may have the same shape as the body of a conventional violin. If desired the pick-up 12 may be applied to or embodied in the body of a typical violin which has been modified to make it substantially non-vibratile. In accordance with the broader aspects of the invention the instrument body 10 may be made substantially non-vibratile and non-resonant in any suitable manner. In practice it has been found desirable to provide a plurality of spaced braces or posts 14 in the interior of the hollow body 10 to connect its upper normally vibratile wall 15 with the bottom of the body 10 to make the upper wall 15 substantially rigid and non-vibratile. The posts 14 are rigidly secured to the top wall 15 and are effective in preventing vibration of the same. The usual openings 16 in the upper body wall 15 may be closed with fabric 17 or the like, to further dampen the body 10. In addition to the posts 14 and the fabric 17 the body 10 may be lined or filled with felt, kapok or the like to lessen or prevent vibration of the body or the resonance of the body. The body 10 is provided with the usual neck 18. The neck 18 is rigid with the body 10 and projects outwardly from the body. The conventional finger-board 19 is provided on the neck 18 and the outer portion of the neck 18 carries the string tensioning pegs 20.

The strings 11 are stretched across the upper face of the body 10 and the fingerboard 19 and constitute the vibratile elements or sound propagating elements of the instrument. In the case illustrated there are four spaced strings 11 which may be considered as the conventional E, A, D and G strings of the violin. The strings 11 are tensioned between a tail piece 21 on the body 10 and the pegs 20 at the outer end of the neck 18. The pegs 20 may be employed to tension and tune the strings 11 in the usual manner. It is a feature of the invention that the strings 11 may be of any desired or selected character. For example, the strings 11 may be metal strings, gut strings, gut string wound with silk or metal, and the different strings may be of different materials and construction. In accordance with the usual practice the strings 11 are graduated in diameter. While the strings 11 may be tuned differently I will herein designate them as the E, A, D and G strings, the E string being the smallest in diameter and the G string being the largest in diameter. Fig. 2 of the drawing illustrates the relationship between the E, A, D and G strings and the several parts of the pick-up 12 which relationship will be hereinafter described.

The pick-up 12 is provided to convert the vibrations of the strings or vibrations produced by the strings into a modulated electric current which in turn may be reproduced as sound truly representative of the tone producing vibrations of the strings. It is a feature of the invention that the pick-up 12 is small, light in weight, and readily arranged on the body 10 of the musical instrument. An opening 22 is formed or cut in the upper wall 15 of the body 10 to receive the pick-up 12. The opening 22 is spaced from the tail-piece 21 in the direction of the neck 18 and is shaped to receive a mounting plate 23 of the pick-up 12. In the particular arrangement illus-

trated in the drawing the opening 22 has a straight outer wall and a curved inner or rear wall. The mounting plate 23 may be a simple casting of aluminum, Bakelite, or other non-magnetic material. The plate 23 rests downwardly against the upper surface of the body wall 15. Suitable screws 24 may secure the mounting plate 23 to the upper wall 15 of the body 10. An opening 25 is provided in the mounting plate 23. The opening 25 is horizontally elongated and its major horizontal axis extends transversely of the strings 11. Two downwardly projecting bosses 26 are provided on the under side of the mounting plate 23. The bosses 26 are adjacent the opposite ends of the opening 25 and project downwardly into the hollow instrument body 10. The bosses 26 are positioned with respect to the opening 25 so that their upper sides or ends constitute upwardly facing shelves or shoulders 27 at the opposite ends of the opening 25.

The electrical pick-up 12 further includes a magnet 28 carried by the bosses 26 of the plate 23 to be within the hollow instrument body 10. The magnet 28 is a permanent magnet and is preferably U-shaped or of the horse-shoe type. The magnet 28 is preferably laminated. I have found that the magnet 28 is of greater strength when formed of two or more relatively thin magnets secured together to constitute a single laminated magnet of the character illustrated in the drawing. In the particular case shown in the drawing the magnet 28 is formed of two layers or laminae which are preferably adhesively secured together by "water glass" or silicate of soda, or the like, to prevent the development of vibration between them. The magnet 28 is arranged with its arms extending in the same general direction as the strings 11 and screws 29 are passed upwardly through openings in the arms of the magnet and are threaded in openings 30 in the bosses 26 to secure the magnet arms to the bosses.

Each arm of the magnet 28 is provided with a pole piece 31. The pole pieces 31 are formed of magnetic material to constitute extensions of the magnet 28. The pole pieces 31 are preferably substantially L-shaped having inner parts or arms 31<sup>a</sup> engaging upwardly against the under sides of the magnet 28. The heads 29<sup>a</sup> of the screws 29 may clamp the pole piece arms 31<sup>a</sup> upwardly against the arms of the magnet 28. Silicate of soda may be employed to adhesively secure the magnet 28 to the bosses 26 and to secure the pole piece arms 31<sup>a</sup> to the magnet arms to prevent rattle and relative vibration at these points. The pole pieces proper, 31, project upwardly or outwardly from their arms 31<sup>a</sup> to be in spaced parallel relation and to be spaced from the arms of the magnet 28. The pole pieces 31 are elongate or rectangular in transverse cross section and have their longest transverse axis substantially parallel with the strings 11. The upper ends of the pole pieces 31 are flat and lie in a plane adjacent or slightly above the plane occupied by the shoulders 27.

The pick-up 12 further includes an induction coil C surrounding each pole piece 31. The coils C are in the nature of wrappings or windings of wire on spools 32. The spools 32 are of insulating material and may rest on the arms 31<sup>a</sup> of the pole pieces to support the coils in position. The pole pieces 31 protrude clear of the upper ends of the coil spools 32. A wire 33 electrically connects the two coils C and a lead 34 extends from each coil C. A clip or terminal 35 is carried by

one of the screws 29 and is electrically engaged by one of the leads 34 whereby the coils C are grounded or connected with the magnet 28. The leads 34 extend through the body 10 to plug jacks 36. The plug jacks 36 are adapted to receive plugs 37 on electrical leads 38 extending to a suitable amplifying and loud speaker unit 39. The plug jacks 36 may be suitably secured in openings in the side wall of the instrument body 10. The invention provides a tone control 40 and a volume control 41 on the instrument body 10 to govern the action or operation of the pick-up 12. The controls 40 and 41 are suitably connected in the coil leads 34. The handles or knobs 40<sup>a</sup> and 41<sup>a</sup>, respectively, of the controls 40 and 41 project from the outer surfaces of the instrument body 10 to be conveniently accessible to the musician.

An important element of the pick-up 12 is a diaphragm or armature 43 responsive to vibration produced by the strings 11 and operable to induce a modulated current in the coil C. It is a feature of the invention that the armature 43 carries the bridge 13 and floats or is supported for controlled or dampened vibration. The armature 43 is an elongate member formed of magnetic material. In the preferred construction illustrated in the drawings the armature 43 is a plate-like member provided on its outer side with a section 43<sup>a</sup> of wood, hard rubber composition, Bakelite or other non-magnetic material. The under side of the armature 43 is flat and substantially horizontal to oppose the upper ends of the pole pieces 31 while the upper side of the armature section 43<sup>a</sup> is curved or convex as best illustrated in Fig. 2 of the drawing. The armature 43 is supported on the shelves or shoulders 27 to be adjacent and in spaced relation to the outer ends of the pole pieces 31. The bridge 13 is supported on the armature 43 and the armature is mounted on the shoulders 27 in such a manner that the assembly of the bridge 13 and the armature 43 may move or vibrate in the desired manner in response to vibration of the strings 11. The bridge 13 may be of typical construction and may be formed of wood, or the like. The upper edge of the bridge 13 has notches 44 receiving the spaced strings 11. The bridge 13 is provided at its lower or inner end with broadened feet 45, which rest on the outer surface of the armature section 43<sup>a</sup>. The opposite end portion of the armature 43 are supported on the spaced shoulders 27.

In accordance with the invention the end portion of the armature 43 under or in close relation to the E and A strings is supported on its shoulder 27 through a relatively unyielding cushion 46. The cushion 46 may be formed of wood, pressed felt, cork, or the like. It is to be understood that the cushion 46 may be partially or slightly yielding. The end portion of the armature 43 under the D and G strings is supported on its shoulder 27 by a yielding cushion. The cushion supporting the last named end of the armature 43 may be laminated and may include a layer 48 of yielding rubber and one or more layers 49 of wood, felt, cork, paper or similar material. The cushion formed of the layers 48 and 49 is preferably somewhat thicker than the cushion 46. Because of this relationship between the cushions 46 and 48-49 the armature 43 is slightly inclined with respect to the plane occupied by the ends of the pole pieces 31. The non-magnetic section 43<sup>a</sup> of the armature 43 has an inclined under surface 50 to compensate for this inclination of the armature 43 so that the bridge 13 is supported in

its correct non-inclined position. A protective or retaining plate 51 may be secured to the upper side of the mounting plate 23 to partially overlie the opening 25. The plate 51 is operable to prevent loss or displacement of the armature 43 and prevents the entrance of objects into the pick-up 12. The plate 51 is preferably formed of non-magnetic material and does not engage the bridge 13 or the armature 43. The assembly of the bridge 13 and armature 43 supported by the cushions 46 and 48-49 is "floating" or capable of limited movement caused by vibration of the vibratile strings 11. When a string 11 is bowed, plucked, or otherwise vibrated the assembly of the floating bridge 13 and armature 43 is put into vibration and the vibration of the armature 43 varies the reluctance of the magnetic circuit of the pick-up 12 inducing a current in the coils C. This current carried by the leads 34 and 38 is amplified and converted into sound by the unit 39, the sound being truly representative of the vibration of the string 11. It will be understood how movement of the armature 43 resulting from vibration of a string or strings 11 disturbs the magnetic field or varies the reluctance of the magnetic field concentrated at the outer ends of the pole pieces 31. The magnetic circuit of the magnet 28 and the pole pieces 31 is linked with the coils C and variation of its reluctance induces a current in the coils which current has characteristics proportional to and truly representative of the vibrations of the string or strings 11.

The cushion 46 supporting the end of the armature 43 carrying the end portion of the bridge 13 which engages the tensioned light E string is substantially unyielding and forms what may be considered a pivotal mounting for the bridge and armature assembly. The cushion 48-49 supporting the other end of the armature and bridge assembly is yielding so that the end of the bridge 13 engaged by the heavy strings D and G may have considerably more movement or vibration than the end of the bridge engaged by the E string. The tensioned strings 11 of course exert a considerable downward pressure on the bridge 13 which maintains the armature 43 in tight engagement with its cushions 46 and 48-49. The lighter E and A strings may in some instances be under greater tension than the heavier D and G strings and may exert a heavier downward force on the bridge 13 and the armature 43. This heavier downward force or pressure is transmitted to the relatively unyielding cushion 46. The relationship between the cushions 46 and 48-49 is such that vibration of the A, D and G strings produces a greater vibration or movement of the armature 46 than vibration of the E string so that the pick-up 12 is more sensitive or more responsive to the vibrations of the A, D and G strings than it is to the vibrations of the E string. Thus the pick-up 12 of the invention automatically compensates for the normal dominance of the E string over the other strings of the instrument. Accordingly, the musician is able to obtain tones of the desired character, intensity and volume from the A, D and G strings with ease. It is to be understood, of course, that the amplifying and loud speaker unit 39 is operable to produce tones from any and all of the strings 11 of any desired volume.

The instrument provided by the present invention may be handled and played in the same manner as any conventional violin class instrument. The pick-up 12 and the associated parts are all light in weight and do not materially affect or

change the appearance of the instrument. The pick-up 12 is located substantially centrally of the instrument body 10 and its principal parts are concealed within the body. The pick-up 12 may be easily and inexpensively embodied in the body of a typical violin type instrument with a minimum of modification.

Having described only a typical preferred form and application of my invention, I do not wish to be limited or restricted to the specific details herein set forth, but wish to reserve to myself any variations or modifications that may appear to those skilled in the art or fall within the scope of the following claims.

Having described my invention, I claim:

1. A pick-up for use on a stringed musical instrument having a vibratory part, the pick-up comprising a magnet having spaced pole pieces, induction coils around the pole pieces, a support member carrying the magnet and having spaced shoulders, an armature in the field of magnetic flux between the pole pieces and having longitudinally spaced portions in supporting engagement with said part, and cushions mounting the ends of the armature on the shoulders whereby the armature is supported independently of the pole pieces to be vibrated by the said part, one of said cushions being more yieldable than the other whereby the armature is more responsive to the vibrations of one end portion of the said part than to the vibrations of the other end portion of said part.

2. A pick-up for use on a stringed musical instrument having a vibratory part, the pick-up comprising a magnet having spaced pole pieces, induction coils around the pole pieces, a support member carrying the magnet and having spaced shoulders, an armature in the field of magnetic flux between the pole pieces and having longitudinally spaced portions supporting the ends of said part, and yieldable material supporting the ends of the armature on the shoulders whereby the armature is responsive to vibration of the said part, the said material on one shoulder being more yieldable than the material on the other shoulder.

3. A pick-up for use on a stringed musical instrument having a vibratory part, the pick-up comprising a support member having spaced shoulders, a magnet carried by the member and having pole pieces, induction coils on the pole pieces, an elongate armature arranged in the field of magnetic flux between the pole pieces and carrying the vibratory part, and cushions on the shoulders having supporting engagement with the opposite end portions of the armature whereby the armature is vibrated by the said part, one of said cushions comprising yielding resilient material, the other cushion comprising substantially unyielding material.

4. A pick-up for a musical instrument having

a hollow body provided with an opening in its upper wall and having a vibratory part, the pick-up including a mounting member on said upper wall entering said opening, a magnet in the body carried by said member and having pole pieces, induction coils around the pole pieces, an elongate armature arranged within the field of magnetic flux between the pole pieces adapted to carry said part to be vibrated by said part, and means supporting two longitudinally spaced parts of the armature on the said member, one of said means being yieldable and vibration dampening, the other of said means being substantially unyielding and vibration dampening.

5. A pick-up for a stringed musical instrument embodying a vibratile part and having a hollow body provided with an opening in its upper wall, the pick-up comprising a mounting member on said upper wall entering said opening, spaced shoulders on the said member, a magnet in the body carried by said member and having pole pieces projecting outwardly, induction coils around the pole pieces, an armature adapted to be vibrated by said part and arranged in adjacent spaced relation to the outer ends of the pole pieces, substantially unyielding cushion means supporting one end portion of the armature on one of the said shoulders and yieldable cushion means supporting the other end portion of the armature on the other shoulder to be responsive to vibrations of the strings.

6. A pick-up for a stringed instrument having a hollow body and a vibratory part, the pick-up comprising a magnet having spaced pole pieces, means supporting the magnet in the body to have its pole pieces project upwardly, induction coils around the pole pieces, an armature arranged in spaced inclined relation to the plane occupied by the upper ends of the pole pieces and supporting the vibrating part, and cushion means supporting the opposite end portions of the armature, the supporting means at the high end of the armature being yieldable, the supporting means at the low end of the armature being substantially unyielding.

7. A pick-up for use on a stringed instrument having a body and a vibratory part, the pick-up comprising a mounting plate to be secured to the instrument body and having an opening, downwardly projecting bosses on the plate at opposite ends of the opening, a magnet secured to the lower ends of the bosses, upwardly projecting pole pieces on the magnet, induction coils around the pole pieces, an armature supporting said part arranged in the opening and in the field of the magnetic flux between the pole pieces, and means supporting the opposite ends of the armature on upper ends of the bosses, one of the said means being yieldable and the other of said means being substantially unyielding.

FREDRAY H. KISLINGBURY.